



# LIFTOFF

Leading the lifting game since 2002

WINNTEC

2T  
OK

WINNTEC

TY SERIES

CE UK CA

EU US

EC.NET



## Workshop Essentials 2025



# Winntec Workshop Essentials Contents

<b>01.</b>	<b>Lifting Equipment</b>		<b>02 - 15</b>	
	» Floor Jacks	02	» Air Hydraulic Jacks	11
	» Liftpads	06	» Bottle Jacks	12
	» Long Chassis Jacks	10	» Air Bottle Jacks	13
	» Forklift & Tractor Jack	10	» Balloon Jacks	14
<b>02.</b>	<b>Wheel Handling Equipment</b>		<b>16 - 21</b>	
	» Smart Carts	16	» Wheel Assist & Wheel Lift	19
	» Smart Discs	19	» Wheel Dollies	20
<b>03.</b>	<b>Workshop Equipment</b>		<b>22 - 41</b>	
	» Electrohydraulic Press	24	» Engine Stand	31
	» Hydraulic Press	25	» Transmission Jack	31
	» Vehicle Lifts	28	» Jack Stands	34
	» Foldable Crane	30	» Miscellaneous	38
	» Battery Lift	31		
<b>04.</b>	<b>Jack the Mech</b>		<b>40 - 41</b>	
	» Detailing Seat	42	» Mobile Energy & Air	40
	» Start Booster	43		



LEMANS 2024 (FR)

## Reaching new Heights

### This is who we are:

Winntec is a leading manufacturer, renowned developer, and global supplier of premium-quality, efficient, and reliable automotive workshop essentials. Our award-winning and patented Smart Carts, Wheel Lifts and Safergo have rocked the automotive industry.

### We don't just manufacture automotive workshop essentials; we redefine them!

User-friendliness is at the heart of our design philosophy, with safety and comfort being amongst the top priorities. Our durable, high-quality products are crafted to meet the ever increasing demands of mechanics—all at competitive prices. Plus, our outstanding customer service ensures you have all the support you need.

### As we look to the future, our goal is clear.

We recognize the unique challenges mechanics face, both in the workshop and on the road. With vehicle and component weights continuing to rise, we're committed to delivering cost-effective solutions for lifting, handling, and transporting that save time and minimize risk.

Winntec lifting products meet NEN-EN 1494:2001+A1:2008 standards and are perfectly serviceable, ensuring reliable, high-quality investments.

No rights can be derived from the contents of this folder. Images shown may differ from reality. Print and text errors reserved.

### WE ARE PROUD TO BE THE DRIVING FORCE BEHIND:



WINNTEC HEADQUARTERS (NL)

# Lifting Equipment Floor Jacks

After we founded Winntec in 2002, we completely redesigned the hydraulic floor jack from the ground up.

The result was an innovative, operator-friendly, and serviceable design that blended the best of European and American features and functionality. We pioneered technologies like TURBO LIFT and 2-SPEED LOWERING, which began as unique features and are now standard on nearly all our jacks.

Today, we offer the most comprehensive range of hydraulic jacks in the industry, with capacities from 1.35 to 32T.

The majority of our jacks undergo rigorous testing, are third-party certified, and come with a straightforward 3-year hydraulic manufacturer's warranty. Alongside our heavy-duty workshop jacks, we also provide lightweight models designed for mobile use.

Quality, safety, and ease of use have always been, and will continue to be, at the core of our operations.

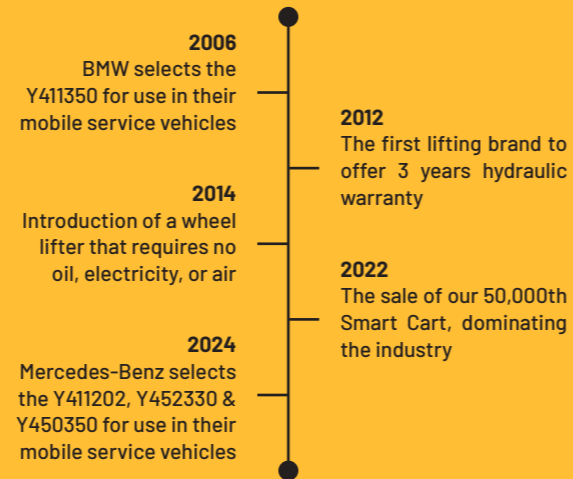

## TURBO LIFT

Allows your jack to rise quickly with the use of the foot pedal



## 2-SPEED LOWERING

Enables your jack to lower slowly under load, yet fast without.



Floor Jack dimensions Values are in mm and kg unless stated otherwise.

Model	Min. H.	Max. H.	Width	Length	Material	Capacity	Weight
Y 411350	80	375	236	501	Aluminum	1.35 T	10
M411355	90	360	247	481	Aluminum/Steel	1.5 T	14
Y 411202	86	418	282	625	Aluminum/Steel	2 T	22
Y420222	75	500	350	705	Steel	2 T	42 kg
Y420250	75	510	343	686	Steel	2 T	32.5 kg
Y420330	120	450	344	618	Steel	3 TN	31 kg
Y420333	76	503	346	672	Steel	3 T	37 kg
Y420336	95	540	350	688	Steel	3.6 T	38.5 kg

## Y411350 - Full Aluminum Jack 1.35T

This premium full aluminum jack is designed for effortless handling and robust performance. Featuring a thick, durable frame and a reinforced lift arm, it ensures reliability during heavy-duty tasks. Built-in bypass and overload valves offer added safety. The two-piece handle includes a quick-lock mechanism, making storage simple and hassle-free.

Specifications	
Min. H.	80 mm
Max. H.	375 mm
Width	236 mm
Length	501 mm
Capacity	1.35 T
Weight	10 kg



### Main Features

- ONLY 10 KG!
- Nylon wheels
- Rubber saddle pad



## M411355 - Aluminum/Steel Jack 1.5T

High-performance aluminum/steel jack that combines portability with advanced functionality. It features powerful TURBO LIFT technology for rapid lifting and a 2-speed lowering mechanism that ensures smooth and precise control. Packaged in a sleek color box, it's the perfect blend of style, performance, and convenience, making it an ideal choice for both professionals and enthusiasts.

Specifications	
Min. H.	90 mm
Max. H.	360 mm
Width	247 mm
Length	481 mm
Capacity	1.5 T
Weight	14 kg



### Main Features

- 2-SPEED LOWERING
- TURBO LIFT
- Rubber saddle pad



## Y411202 - Aluminum/Steel Jack 2T

Combining durability and ease of use in a lightweight design. Built with a robust aluminum/steel construction, this jack features Turbo Lift technology, allowing for quick and effortless lifting and 2-speed lowering ensures smooth, controlled lowering for safe operation every time. A foot pedal provides hands-free convenience, while the PU wheels minimize noise and protect sensitive surfaces.

Specifications	
Min. H.	86 mm
Max. H.	418 mm
Width	282 mm
Length	625 mm
Capacity	2 T
Weight	22 kg





### Main Features

- 2-SPEED LOWERING
- TURBO LIFT
- Foot pedal
- PU wheels
- Rubber saddle pad



## Y420250 - Ultra Low Floor Jack 2T

This jack features an ultra-low profile design combined with TURBO LIFTER technology. It starts at just 75 mm and reaches an impressive maximum height of 510 mm. The PU wheels minimize noise and reduce the risk of damage to showroom floors. It comes with heat-treated chromed pump pistons and a chromed main ram. Like all our other jacks, it is equipped with cardan transmission.

Specifications	
Min. H.	75 mm
Max. H.	510 mm
Width	343 mm
Length	686 mm
	2 T
	32.5 kg





### Main Features

- 2-SPEED LOWERING
- TURBO LIFT
- Rubber saddle pad
- PU wheels

## Y420330 - Compact Floor Jack 3TN

Designed for efficiency and ease of use, featuring innovative noise-reducing PU wheels that provide smooth and quiet operation. Equipped with a rubber saddle pad to ensure a secure grip on the vehicle and to prevent damage. Featuring 2-speed lowering and Turbo Lift technology. The ram and pistons are chrome-plated for enhanced durability and longevity.

Specifications	
Min. H.	120 mm
Max. H.	450 mm
Width	344 mm
Length	618 mm
	3 TN
	31 kg



### Main Features



- 2-SPEED LOWERING
- TURBO LIFT
- Rubber saddle pad
- PU wheels



EXCELLENT PRICE - QUALITY RATIO

## Y420222 - Ultra Low Floor Jack with Integrated Jack Stand Function 2T

This ultra-low floor jack (75 mm) features an integrated jack stand function and a maximum lifting height of 500 mm. It includes hold-to-run control for added convenience. The PU wheels are designed to reduce noise and protect floors from damage. The saddle is covered with a rubber pad to prevent any harm to the underside of the chassis, while the handle is equipped with a bumper to safeguard the car from scratches.

Specifications	
Min. H.	75 mm
Max. H.	500 mm
Width	350 mm
Length	705 mm
	2 T
	42 kg



### Main Features



- INTEGRATED JACKSTAND FUNCTION
- 2-SPEED LOWERING
- TURBO LIFT
- Hard-chromed ram and pistons
- Auto-lock



INTEGRATED JACK STAND FUNCTION

## Y420333 - Ultra Low Floor Jack 3T

"The ULTIMATE" floor jack combines an ultra-low profile with impressive high reach, making it ideal for low-clearance vehicles. It delivers powerful performance, while the advanced 2-Speed Lowering and Turbo Lift technologies ensure fast, efficient lifting and lowering. The noise-reducing PU wheels ensure smooth and quiet operation. The jack is equipped with a rubber saddle pad and a convenient foot pedal.

Specifications	
Min. H.	76 mm
Max. H.	503 mm
Width	346 mm
Length	672 mm
	3 T
	37 kg





### Main Features

- 2-SPEED LOWERING
- TURBO LIFT
- Rubber saddle pad
- PU wheels
- Foot pedal



## Y420336 - Low Floor Jack High Reach 3.6T

Powerful 3.6-ton jack designed for both low entry height and impressive 540 mm lifting capacity. It features advanced 2-Speed Lowering and Turbo Lift technologies for quick, efficient operation. The rubber grip and rubber pad provide added stability and protection, while the chrome-plated pistons ensure durability. Industrial-grade polyamide wheels deliver smooth, reliable performance. Additionally, the welded pump makes it a reliable tool for any heavy-duty lifting task.

Specifications	
Min. H.	95 mm
Max. H.	540 mm
Width	350 mm
Length	687 mm
	3.6 T
	38.5 kg



### Main Features

- 2-SPEED LOWERING
- TURBO LIFT
- Rubber grip
- Polyamide wheels
- Rubber pad
- Welded pump



MAXIMUM HEIGHT 540 MM



© COPYRIGHTED BY TOP GEAR



# Lifting Equipment Dedicated Liftpads



## Y490000 - Liftpad X

Provides safe lifting without damaging your vehicle, featuring an X-groove for precise alignment. Fully compatible with most floor jacks.

Perfect fit for: Y411202, Y420250, Y420303, Y420330, Y420333, Y420336.



## Y490010EV - Liftpad EV

Designed for lifting vehicles that require an adapter, with built-in magnets on the bottom for a secure and stable hold.

Perfect fit for: Y411202, Y420250, Y420303, Y420330, Y420333, Y420336.



## Y490020 - Liftpad S

Ensures safe lifting without damaging your vehicle, featuring an X-groove and an adapter slot for easy use with lifting adapters.

Perfect fit for: Y411350, Y420222 & M411355.



Liftpad dimensions Values are in mm and grams.

Model	A	B	C	D	E	F	G	Weight
Y490000	122	43	10/13	92	104	106	118	400
Y490010	112	20	∅ 75	92	104	106	118	150
Y490020	110	43	10/13	80	-	-	100	300

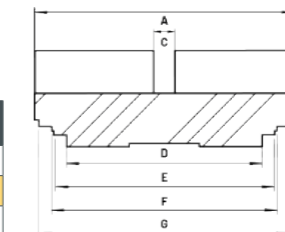

## Lifting Adapters

More and more vehicles, especially electric vehicles (EVs), require lifting adapters for safe lifting.

Winntec's Liftpads are designed to fit the majority of these adapters to ensure safe lifting and reduce the risk of damage.

Additionally, our pads are completely PFAS and PAHS free.



## Y411350-42 - Fully Covering Saddle Pad

Perfect fit guaranteed with our: Y411350.



## M411355-01 - Inlay Saddle Pad Yellow

Perfect fit guaranteed with our: M411355.



## Y420250-34 - Inlay Saddle Pad

Perfect fit guaranteed with our: Y420250, Y420330 & Y420333.



## Y420336-42 - Inlay Saddle Pad

Perfect fit guaranteed with our: Y420336.



## Y411202-45 - Fully Covering Saddle Pad

Perfect fit guaranteed with our: Y411202, Y420250, Y420330 & Y420333.



## Y411202-51 - Handle Bumper

Upgrade your jack today with our Heavy-Duty Handle Bumper. Designed to absorb impact and minimize wear, this bumper is a reliable solution for protecting your equipment and customer's vehicle.

Perfect fit guaranteed with our: Y411202, Y420250, Y420330 & Y420333.

Inner diameter: 32 mm  
Outer diameter: 50 mm  
Length: 410 mm



**Our rigid liftpads ensure damage-free lifting, with the S and EV pads being ideal for cars that need an adapter.**



“

**We support & sponsor multiple racing teams, fueling their pursuit of excellence & driving product innovation.**

# Lifting Equipment Long Chassis Jacks

## Long Chassis Jacks 2-10T

Our Long Chassis Jacks are designed for heavy-duty lifting, featuring foot pedals for quick elevation and ergonomically designed handles with a release button for gradual lowering. Additionally, these jacks are equipped with an automatic overload safety valve and durable swivel castors for easy maneuverability.

### Main Features

- **ERGONOMIC HANDLE**
- Foot pedal
- Overload safety valve
- Durable swivel castors



Long Chassis Jack dimensions Values are in mm and kg unless stated otherwise.

Model	A	B	C	D	E	Capacity	Weight
Y420200	138	800	396	1,310	1,285	2 T	58
Y420301	130	600	325	1,400	1,330	3 T	65
Y420500	150	680	366	1,505	1,345	5 T	90
Y421000	160	680	485	1,635	1,355	10 T	145

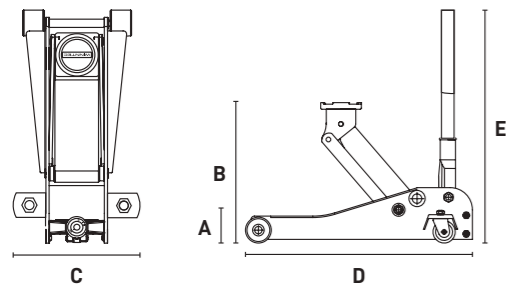

# Lifting Equipment Forklift & Tractor Jack

## Y454000 - Forklift & Tractor Jack 4/5T

Our forklift jack is equipped with dual lifting points (4/5T), 2-speed lowering, and a durable chrome-plated ram and pump piston. The extended lower arm is just 65mm, providing easy access under forklift trucks, while the 416mm upright piston is ideal for lifting tractors and farm machinery. It offers a hydraulic lift of 355mm on the forklift arm and 309mm on the upright piston. The jack also features a removable handle and a compact design.

### Main Features

- **2-SPEED LOWERING**
- 2-Position lift pad
- High-strength framework

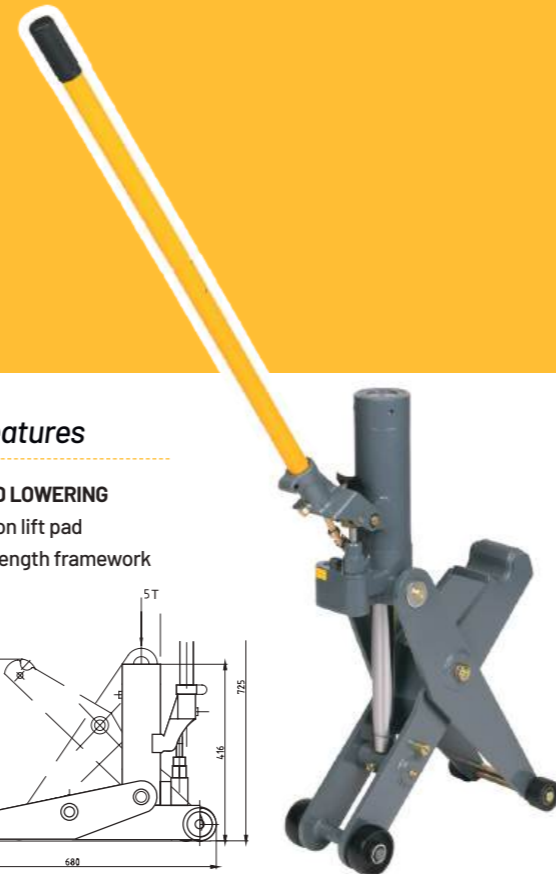
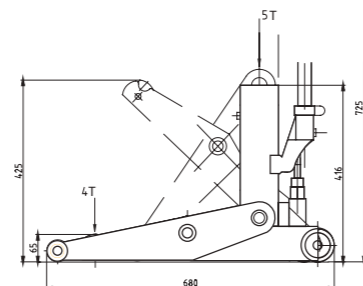

Forklift Jack dimensions Values are in mm and kg unless stated otherwise.

Model	Max. H. 1	Max. H. 2	Min. H. 1	Min. H. 2	Capacity	Weight
Y454000	425	725	65	416	4/5 T	45

# Lifting Equipment Air Hydraulic Jacks

## Y432024 - Single Stage Air Service Jack 24T

This single-stage air service jack delivers 24 tons of lifting power with premium hydraulic and pneumatic components. Designed for top performance at a competitive price, it allows safe air-powered lifting and lowering, eliminating the need for manual descent on heavy trucks. The Y432024 includes 3 extensions (20mm, 50mm, 100mm) and an 85mm extension screw. Heavy-duty wheels ensure durability.

### Main Features

- **HARD CHROMED PISTON**
- Pneumatic descend
- Dead-man control
- Extension screw
- 3 extensions

Air Hydraulic Jack dimensions Values are in mm and kg unless stated otherwise.

Model	A	B	C	D	E	F	G	Capacity	Weight
Y432024	215	141	85	525	1,240	265	441	24 T	40
Y432032	150	73	66	480	1,300	290	289	32/16 T	38

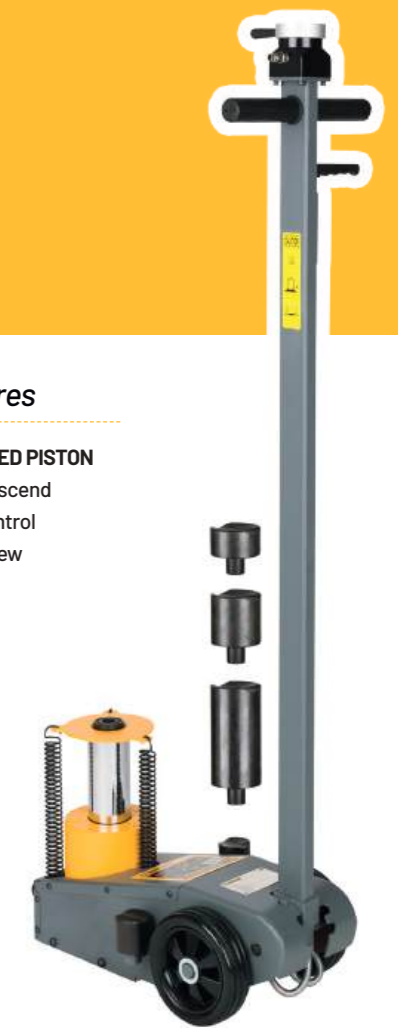
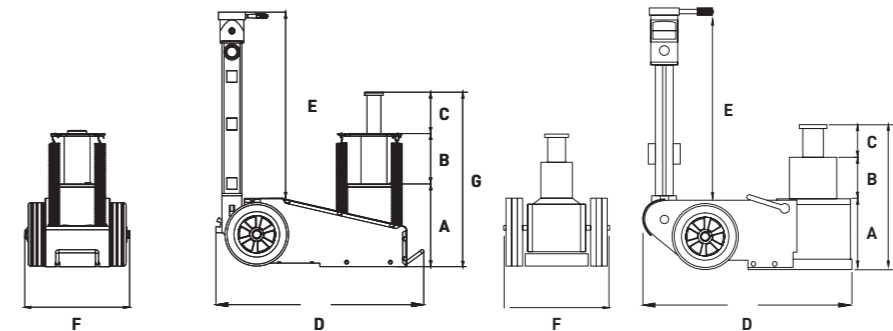

## Y432032 - Telescopic Air Service Jack 32T

This dual-stage air service jack features a low entry height of just 150mm and a hard-chromed piston. With a 32/16 ton capacity and compact design, it's perfect for both workshop and roadside assistance. Air-controlled ascent and descent provide maximum safety. It comes with two extensions (45mm and 100mm).

### Main Features

- **HARD CHROMED PISTONS**
- Pneumatic descend
- Dead-man control
- Only 150mm min. height
- Comes with 2 extensions



## GT260MM-EXT

Extension for the Y432032 that increases its reach by 260mm.



\* Reach out to us, and we'll gladly share the test results.

# Lifting Equipment Bottle Jacks

## Bottle Jacks 2-30T

Highly versatile and suitable for a wide range of applications, including pushing, bending, pressing, and straightening. Each model features a cast iron base, polished main ram, and a solid, chrome-plated pump linkage. Tested to meet the latest European standards, they offer overload protection and can be used in both horizontal and vertical positions.

All models, except the Y413000 and Y411000, come with a twist top for precise height adjustments.



### Main Features

- CHROMED PISTONS
- Easy maintenance
- Heat-treated saddle



### Bottle Jack dimensions

Values are in mm and kg unless stated otherwise.

Model	Base Plate	Min. H.	Lifting H.	Adjustable H.	Max. H.	✋	⚖️
Y410200	96 x 93	158	90	60	308	2 T	2.3
Y410400	112 x 104	180	110	60	350	4 T	3.3
Y410600	116 x 116	197	125	60	382	6 T	4.4
Y410800	120 x 120	205	125	60	390	8 T	5.4
Y411000	180 x 118	120	100	-	260	10 T	6.4
Y411200	140 x 135	214	125	60	399	12 T	7.2
Y411500	140 x 140	225	140	60	425	16 T	8.3
Y412000	155 x 140	244	145	60	449	20 T	10.5
Y412001	155 x 140	190	90	60	340	20 T	9
Y413000	175 x 160	285	180	-	465	30 T	14.6

## Y411000 - 10T

The telescopic Y411000 features 2 extensions (45 mm and 6 mm), internally machined oil passages and smooth bearing surfaces, ensuring superior performance.



# Lifting Equipment Air Bottle Jacks

## Air Bottle Jacks

Highly versatile and suitable for a wide range of applications, including pushing, bending, pressing, and straightening. Each model features an air regulator, extension screw, specially heat-treated cylinder wall, chromed ram, and a welded base to ensure reliability. Filters prevent contaminants from entering the air/hydraulic system.

### Main Features

- WELDED BASE
- Extension screw
- High speed air motor
- Chromed ram

## Y432021 - Low Profile Air Bottle Jack 20T

Designed to handle up to 20 tons with ease, it features a welded base that enhances stability and extends the service life of the unit. The jack is equipped with a chrome main ram and an aluminum air motor, ensuring exceptional durability and long-term performance. An integrated air filter and regulator, pre-connected to the hose, provide clean and precise operation for consistent results.



## Y432020 - Air Bottle Jack 20T

Designed and built to handle the toughest jobs with unmatched durability and reliability. This air bottle jack features an air regulator, chrome ram, welded base, and robust return springs. They are designed to perform flawlessly under demanding conditions. Every unit is rigorously hand-tested before shipping, ensuring maximum reliability and consistent performance on every task.



## Y432003 - Air Bottle Jack On Trolley 20T

The Y432020 Jack, mounted on a convenient trolley, is designed for effortless maneuverability and superior performance. Engineered to tackle the toughest jobs, it boasts unmatched durability and reliability. Key features include an air regulator, chrome ram, welded base, and heavy-duty return springs, ensuring flawless operation even in the most demanding conditions. Each unit undergoes rigorous hand-testing before shipping, guaranteeing maximum reliability and consistent results every time.



### Air Bottle Jack dimensions

Values are in mm and kg unless stated

Model	Base Plate	Min. H.	Max. H.	✋	⚖️
Y432021	180 x 115	148	260	20 T	9
Y432020	220 x 175	245	475	20 T	16.5
Y432003	300 x 150	253	483	20 T	26

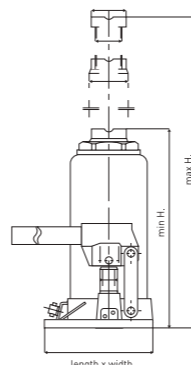



# Lifting Equipment

## Balloon Jacks

### Balloon Jacks

Highly versatile and suitable for a wide range of applications, including pushing, bending, pressing, and straightening. Each model features an air regulator, extension screw, specially heat-treated cylinder wall, chromed ram, and a welded base to ensure reliability. Filters prevent contaminants from entering the air/hydraulic system.



### Y422002 - Pneumatic Balloon Jack 2T

Lifts quickly and is easily positioned on a car lift. A safety valve prevents over-inflation, while the internal telescopic stabilizer (made from ASTM-513 steel) ensures stability.

#### Main Features

- PRECISE HEIGHT CONTROL
- IDEAL ON 4 POST LIFT
- INTERNAL TELESCOPIC STABILIZER
- Safety valve
- Low profile
- 2-Stage



### Exploring Winntechnology

In the second episode of Exploring WINNTEchnology, we dive into the unique features that set our balloon jacks apart.



### Y422012 - Pneumatic Balloon Jack 2T

Our Y422002 equipped with a handle and wheels for easy positioning under the vehicle.

#### Main Features

- PRECISE HEIGHT CONTROL
- HIGHLY MANEUVERABLE
- INTERNAL TELESCOPIC STABILIZER
- Safety valve
- Low profile
- 2-Stage



**Product dimensions** Values are in mm and kg unless stated otherwise.

Model	A	A'	B	B'	D	E	Weight	Capacity
Y422002	300	360	125	185	400	-	2 T	15
Y422012	300	360	125	185	1,000	280	2 T	16

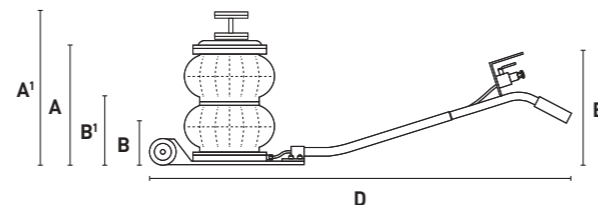

**Lifting solutions for every application, whether in the shop or for roadside assistance.**



“

**Winntec Smart Carts are the #1 choice in motorsports for their durability, comfort and speed!**

# Wheel Handling Equipment

## For cars and vans



### Y471147HD Classic - Smart Cart Ø 76 cm

Our lightweight, high-capacity Classic Smart Cart features patented **LOADSHIFT™** technology and is equipped with a unique push-slide-secure automatic locking system and made from durable powder-coated steel. It comes with maintenance-free foam-filled tires that leave no traces.

#### Main Features

- **REQUIRES 3x LESS EFFORT TO TILT/LIFT**
- Auto open/close grippers
- Handles tires and wheel assemblies
- Foam filled tires leave no stripes



**Product dimensions** Values are in mm and kg unless stated otherwise.

Model	Height	Width	Depth	Reach Ø		
Y 471147	1,385	610	695	up to 76	200	20.5
Y 471148	1,385	610	695	up to 83	220	25

### Y4711SPP - Push Pull Ext Kit

OPTIONAL retro-fit extender to increase the carrying capacity of your Smart Cart, while the Push-Pull lever ensures a quick release of the load.



### Y471147HD-PW - Wheel Kit

OPTIONAL retrofit kit to replace the wheels of the Y471147HD with those of the Y471148HD. The kit includes 2 wheels, 2 axle caps, and 2 bushings.



### Y471148EXT - Extender Kit

OPTIONAL bolt-on/off retro-fit extender with rubber grips to increase the carrying capacity of your DOMINATOR. Easy installation and removal.



### Y471148HD Dominator - Smart Cart Ø 83 cm

After changing the industry with our Classic Smart Cart, domination is next: The new Dominator, featuring patented **LOADSHIFT™** technology, is designed to handle larger loads with ease. It boasts an integrated kick pedal, redesigned stainless steel arms and a bracket set for carrying a Smart Disc.

#### Main Features

- **REQUIRES 3x LESS EFFORT TO TILT/LIFT**
- **3 + 7 YEARS WARRANTY** (upon activation)
- Solid rubber tires with cast alu rims
- Spring-operated integrated kick pedal
- Adjustable top plate with rubber grips
- Comes with brackets for a Smart Disc\*



### Y471123 - Smart Disc

Our second generation Smart Disc ensures greater mobility and flexibility, as loads of up to 160 kg can be moved effortlessly. Perfect for showcasing tire sets in the showroom.

Additionally, the Smart Disc can be paired with our Y471147HD and Y471148HD Smart Carts to enhance their swiftness, efficiency, and ease of use!



**Product dimensions** Values are in mm and kg unless stated otherwise.

Model	Ø	Height		
Y 471123	680	85	160	3.5



### Y472270 - Wheel Assist ERGO+

The Winntec Wheel Assist is a patented standalone workshop tool that uses powerful gas springs, enabling technicians to quickly and easily remove and replace wheels while maintaining an ergonomic position.

Distance between rollers:  
Center-to-center: 420 mm  
Minimal: 375 mm

#### Main Features

- **NO HOSES**
- The power of simplicity
- Maintenance free
- Fender protection



**Product dimensions** Values are in mm and kg unless stated otherwise.

Model	Height	Width	Depth		
Y 472270	1,800	685	720	45	42
Y 472280	1,730	930	520	70	45

### Y472280 - Wheel Lift NXT

Swiftly lift and lower wheel assemblies from floor to shoulder height while maintaining an ergonomic position. Patents pending. Operates with the majority of premium cordless drill brands.

Distance between adjustable rollers:  
Center-to-center: A. 500 mm B. 420 mm  
Minimal: A. 452 mm B. 372 mm

#### Main Features

- **NO HOSES**
- Floor to shoulder height
- Precise positioning
- Minimal footprint



\* Cordless drill not included

# Wheel Handling Equipment For trucks

## Y471105 - Wheel Dolly

Quickly and efficiently remove wheel assemblies. Its ergonomic design reduces the risk of back strain injuries. Equipped with adjustable extended rollers and rubber wheels with a steel core.

### Main Features

- QUICK DETACH HANDLE
- Extended rollers - 290 mm
- Steel core rubber wheels



## Y471106 - Hydraulic Wheel Dolly

This lightweight, portable dolly features a hydraulic unit, enabling the operator to work in close proximity to the vehicle, making it ideal for roadside service. Its shock-absorbing casters ensure a smooth ride.

### Main Features

- CARRY HANDLE & BELT
- Maximum mobility
- Fast positioning



**Product dimensions** Values are in mm and kg unless stated otherwise.

Model	Length	Width	Height		
Y471105	1,150	700	250/755	220	15
Y471106	900	450	310	160	29



“

**Our Smart Carts and Wheel Lifts form a strong duo.  
Time savings guaranteed!**



“

**Our welded-frame presses are precision-engineered to handle a wide range of demanding tasks.**

# Workshop Equipment

## Electric Industrial Presses

### Electrohydraulic Industrial Presses 20-50T

These feature a 2-speed hand pump, movable cylinder, and can be operated by both foot and hand for maximum convenience. Built with a durable welded frame, they excel in pressing, bending, bonding, and straightening. Perfect for heavy-duty tasks, such as the removal and installation of universal joints, bearings, pulleys, and wrist pins. Each press includes two precision V-blocks for accurate positioning.

- ⚡ EASIER OPERATION
- ⚡ AUTOMATION & INTEGRATION
- ⚡ Faster response times
- ⚡ Less maintenance
- ⚡ Reduced risk of leaks
- ⚡ Improved control - higher precision

#### Y461730E - Press 30T

- 2-SPEED HAND PUMP
- Movable cylinder (left-right)
- Foot and/or hand operation



#### Y461720E - Press 20T

- 2-SPEED HAND PUMP
- Movable cylinder (left-right)
- Foot and/or hand operation



#### Y461750E - Press 50T

- 2-SPEED HAND PUMP
- Movable cylinder (left-right)
- Foot and/or hand operation



Press dimensions Values are in mm & kg unless stated otherwise.

Model	Height	Depth	Width	V	Power	⚡	👤
Y461516	1,015	134	678	-	-	15 T	57
Y461520	1,830	540	850	-	-	20 T	101
Y461533	1,850	540	840	-	-	30 T	137
Y461555	1,850	650	1,080	-	-	50 T	244
Y461720E	1,830	540	990	230	500 W	20 T	116
Y461730E	1,850	540	990	230	500 W	30 T	152
Y461750E	1,850	650	1,245	230	500 W	50 T	250

# Workshop Equipment

## Industrial Presses

### Industrial Presses 15-50T

Our welded-frame presses are expertly designed to handle a variety of tasks, including pressing, bending, bonding, and straightening. They are essential for the removal and installation of universal joints, bearings, pulleys, and wrist pins. Each press is equipped with two V-blocks for easy and secure positioning, a 2-speed hand pump for efficient operation, and a movable cylinder adjustable from left to right for enhanced flexibility and convenience.

#### Y461516 - Bench Top Press 15T

Our Bench Top Press combines power, precision, and convenience in a compact design. This space-saving press is perfect for workbench use, delivering exceptional reliability for a variety of applications. Whether you're working on small components or intricate tasks, the press offers the performance and durability professionals expect, making it a reliable choice for garages, workshops, and industrial settings.

- BENCH MODEL
- 2-SPEED HAND PUMP
- MOVABLE CYLINDER (LEFT-RIGHT)



#### Y461533-PS

Punch Set



#### Y4615XX-PC

Protective Cover



#### Y461520 - Press 20T

- 2-SPEED HAND PUMP



#### Y461533 - Press 30T

- PNEUMATIC FOOT OPERATION
- 2-SPEED HAND PUMP
- MOVABLE CYLINDER (LEFT-RIGHT)



#### Y461555 - Press 50T

- PNEUMATIC FOOT OPERATION
- 2-SPEED HAND PUMP
- MOVABLE CYLINDER (LEFT-RIGHT)





“

***Our extensive range is generally ergonomically designed and engineered to reduce injury risk.***

# Workshop Equipment Vehicle Lifts

## Y475051 - IN-SYNCH2 2.5T

Easy to maneuver and offering open undercarriage access, it features quick-connect fittings for rapid (dis-)assembly and automatic remote release safety. Synchronized lifting is ensured by our patented valve blocks.

### Main Features

- OPEN UNDERCARRIAGE ACCESS
- Highly maneuverable
- Lifts cars, vans and SUVs



## Y475052 - RAZZO1 2.5T

This versatile mini lift, with a 2,500 kg weight capacity, uses an industrial air-hydraulic foot pump for smooth lifting of cars, vans and SUVs. Equipped with a mechanical safety lock and check valve, it ensures secure operation.

### Main Features

- HIGHLY MANEUVERABLE
- Lifts cars, vans and SUVs
- Mechanical safety lock



**Product dimensions** Values are in mm and kg unless stated otherwise.

Model	Min. H.	Max. H.	Width	Length	Pump	Inlet P.	Weight	Capacity
Y475051	85	455	300	1,800	350 Bar	7 - 10 Bar	2.5 T	95
Y475052	110	630	400	1,120-1,620	700 Bar	7 - 10 Bar	2.5 T	89

## Y475400 - Ultra Low Scissor Lift 3.2T

This lift features four synchronous cylinders for smooth, synchronized lifting. Floor fixation is optional. Limit devices enhance cylinder durability and ensure operator safety. The load-bearing ramp extends the platform to 2,000mm, making it ideal for SUVs and commercial vehicles. The anti-slip patterned platforms are treated for superior grip, corrosion resistance, and long-lasting durability. The integrated PLC features a self-testing function, offering fault diagnosis and ensuring safe voltage.

### Main Features

- LOAD-BEARING RAMP
- Automatic balancing
- Floor fixation optional



## Y475054 - Ultra Low Scissor Lift 3.5T

This lift features four synchronous cylinders for smooth, synchronized lifting. Floor fixation is optional, and mobility tools are included for easy relocation. Limit devices enhance cylinder durability and ensure operator safety. The load-bearing ramp extends the platform to 2,114mm, making it ideal for SUVs and commercial vehicles. The anti-slip patterned platforms are treated for superior grip, corrosion resistance, and long-lasting durability.

### Main Features

- LOAD-BEARING RAMP
- Automatic balancing
- Floor fixation optional



**Product dimensions** Values are in mm and kg unless stated otherwise.

Model	Min. H.	Max. H.	Width	Length	Inlet P.	Frequency	Voltage	Motor Power	Weight	Capacity
Y475400	105	1,900	585 / 2,020	1,460 / 2,000	6 - 8 Bar	50 Hz	400 V	2.2 kW	3,200	810
Y475054	105	1,000	530 / 2,010	1,500 / 2,114	6 - 8 Bar	50 Hz	230 V	2.2 kW	3,500	690





# Workshop Equipment

## Gearbox, Battery & Engine Service

### Y440104 - Foldable Crane 1T

This CE certified crane is designed to lift heavy vehicle parts like engines and transmissions, with three lifting arm positions (1,000 kg, 750 kg and 500 kg) for flexibility. It features foldable legs for easy storage, a dual-speed hydraulic pump that reduces strokes by half, and durable wheels. Safety is ensured with a "dead man" safety mechanism and overload valve.

**Crane dimensions** Values are in mm and kg unless stated otherwise.

Y440104			
P1	1,000	H1 min.	334
P2	750	H2 min.	214
P3	500	H3 min.	94
A	1,405	H1 max.	2,120
B	80	H2 max.	2,210
C	1,499	H3 max.	2,300
D	1,009		1,000
E	125		74

#### Main Features

- **THREE LIFTING ARM POSITIONS**
- **DEAD MAN'S CONTROL**
- Foldable legs
- Dual-speed hydraulic pump



### Y440105

Drop-forged steel engine leveler (550 kg) with heat-treated and fully adjustable 1,000 mm load chains.



### Y475060 - Battery Lift 1.5T

Precise and efficient handling of heavy batteries. The upper platform features flexible tilt adjustment for easy positioning, while the lower platform slides in all directions for perfect alignment. Equipped with auto-lock protection, 8 rubber pads, anti-slip fasteners, and 2-speed lowering. This lift is an essential tool for any battery replacement or maintenance task.

#### Main Features

- **SUPPORTS HEAVY LOADS**
- Flexible tilt adjustment
- 360-Degree sliding base
- Enhanced safety features

**Product dimensions** Values are in mm and kg unless stated otherwise.

Model	Min. H.	Max. H.	Width	Length	Pump	Inlet P.		
Y475060	800	1,800	800	1,566	700 Bar	8 Bar	1,500	450



### Y450102 - Engine Stand 450KG

Easily position and support your engine during repairs or maintenance. The adjustable arms ensure a perfect fit for various engine sizes. With the ability to rotate 360° using the handle, you can easily access all parts of the engine. A locking pin securely holds the stand in place at any of the 8 positions.

**Product dimensions** Values are in mm and kg unless stated otherwise.

Model	Height	Width	Length		
Y450102	860	750	760	450	19

#### Main Features

- **LOCKABLE IN 8 POSITIONS**
- Stable base
- Adjustable arms
- Rotates 360° with handle



### Y451555 - Transmission Jack 550KG

Its superior stability and efficient pump system ensure a fast and precise approach. Suitable for installing and dismantling gearboxes, engines & couplings. For use in pits and underneath elevated vehicles.

**Product dimensions** Values are in mm and kg unless stated otherwise.

Model	Min. H.	Max. H.	Width	Length		
Y451555	1,171	1,989	573	542	550	31
A D A P	-	-	303	485	-	11

#### Main Features

- **HOLD-TO-RUN CONTROL**
- Wide base with swivel wheels
- Foam block to protect vehicle

### Y451555ADAP

Adapter with adjustable arms and 360° rotatable handle. The locking pin secures in any of the 8 positions.

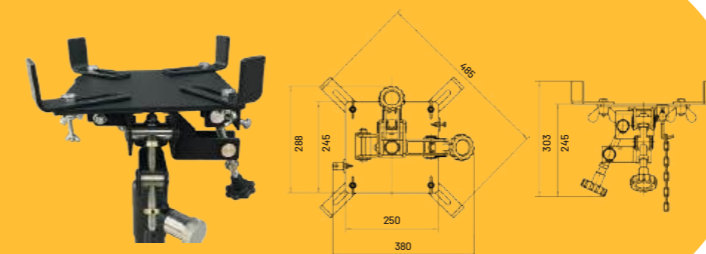



“

**We select premium components, maintain strict quality control, and provide a 3-year hydraulic warranty.**

# Workshop Equipment

## Jack Stands

### Y450301 - Jack Stand 3T

- RATCHET TYPE
- AUTOMATIC LOCKING
- Carrying handle



### Y451600 - Jack Stand 6T

- RATCHET TYPE
- AUTOMATIC LOCKING
- Carrying handle



### Y452300 - Jack Stand 3T

- PIN TYPE
- LARGE PU SUPPORT PAD



### Y452600 - Jack Stand 6T

- PIN TYPE
- LARGE PU SUPPORT PAD



### Y450350 - Fast Lock Jack Block 3.5T

This innovative device replaces your jack stand.

With an adjustable height range of 217 mm to 352 mm, it is suitable for a variety of jacks and vehicle sizes. Easy to install, featuring a spring mechanism for smooth operation, and a safety pin for added security.



UNIVERSAL JACK STAND REPLACEMENT

### Y452330 - Jack Stand 3T

Our premium, toughest jack stand is designed for maximum stability, featuring a large 310 mm base and extra-large foot pads. It is equipped with a durable, 100 mm diameter, replaceable PU saddle pad. The jack stand features a pin-type design and is TÜV and GS certified. Its robot-welded construction ensures exceptional durability.



NEW!



ONLY 300MM MINIMUM HEIGHT

### Y451205 - Low Profile Jack Stand SET 12T

This low-profile jack stand features a handle and wheels for easy positioning. The pin-type support column adjusts to five height positions.

- PIN TYPE
- SOLD AS A PAIR
- Low profile handle
- Nylon wheels



### Y452205 - Low Profile Jack Stand SET 22T

This heavy-duty, welded jack stand set features wheels and a detachable handle. The multi-angle handle sockets allow for easy storage and safe positioning under the vehicle.

- PIN TYPE
- SOLD AS A PAIR
- Low profile handle
- Nylon wheels



### Y451206 - High Reach Jack Stand 12T

This heavy-duty, high-reach welded jack stand features a detachable handle, multi-angle handle socket, and wheels for easy positioning under the vehicle.

The pin-type support column adjusts to various height positions, reaching up to 971 mm, making it ideal for tire service and general trailer support jobs. Sold individually.

- PIN TYPE
- SOLD INDIVIDUALLY
- Low profile handle
- Nylon wheels

REACH UP TO 971 MM

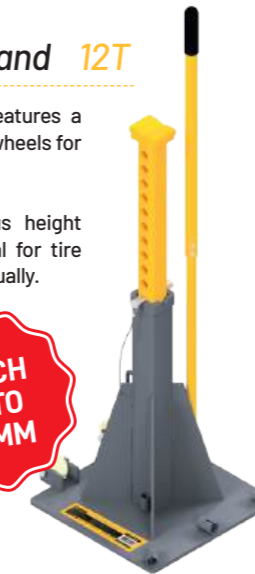

Jack Stand dimensions Values are in mm and kg unless stated otherwise.

Model	Min. H.	Max. H.	Width	Length	Ø	Weight	Capacity
Y450301	305	450	185	209	-	3 T	7
Y451600	395	625	263	293	-	6 T	14
Y452300	322	465	-	-	254	3 T	5
Y452600	404	604	-	-	341	6 T	11
Y452330	300	451	-	-	310	3 T	9
Y450350	217	352	40	90	-	3.5 T	1.5
Y451205	302	450	280	220	-	12 T	20
Y452205	402	575	333	280	-	22 T	42
Y451206	601	971	423	370	-	12 T	29



Robotic Welding



Universal Jack Stand

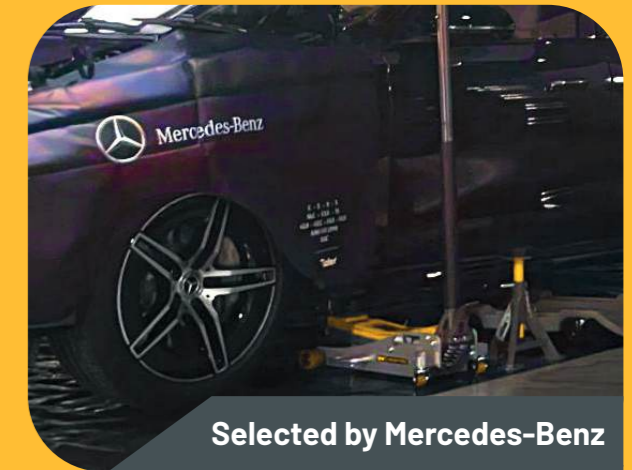

Selected by Mercedes-Benz



Extensive Product Lineup



“

***Our jack stands provide the perfect support, ensuring safety and stability after lifting your vehicle.***



# Winntec JTM Series JACK THE MECH

Designed for the pro - available to all

Winntec's Jack The Mech products are renowned for their high quality and durable construction. They are user-friendly and adaptable to individuals with varying levels of experience, making them a reliable choice for both professionals and enthusiasts.

Launched in 2022, 20 years after the founding of Winntec, the Jack The Mech range is specifically designed to cater to both home tinkerers and professionals.



## JTM101224 - Start Booster 12/24V

This 12/24V start booster delivers a powerful 10,000A capacity, making it an indispensable tool for roadside service professionals. Engineered for reliability and efficiency, it features advanced clamp sensors that proactively alert users to resistance issues before initiating a start, ensuring safety and optimal performance.

### Main Features

- START BOOSTER 10,000A 12V / 5,000A 24V
- Multifunctional LED light
- Multiple safety functions integrated



## JTM200010 - Mobile Energy & Air

This versatile mobile battery booster is an essential tool for a variety of applications, including boats, motorhomes, and cars, as well as for everyday use in workshops, showrooms, and parking lots. It provides powerful jump-starting power and features a compressor with automatic start-stop functionality. The integrated power bank keeps your devices charged, while the multi-functional LED light enhances visibility in any condition.

### Main Features

- START BOOSTER 2,000 A
- COMPRESSOR Auto-start-stop, 10 bar / 145 PSI
- POWER BANK High-Capacity 55.5 Wh
- LED Light Multifunctional



## JTM400000 - Detailing seat

This sturdy workshop seat features a durable carbon steel inner frame and convenient onboard storage. The premium swivel casters - two of which are lockable - ensure mobility and stability. Its ergonomic cradle-style seating at a comfortable height is perfect for detailing, painting, repairing and polishing.

Model	Size	kg
JTM101224	448 x 143 x 435 mm	10.5 kg
JTM200010	280 x 180 x 135 mm	2.5 kg
JTM400000	590 x 280 x 332 mm	5 kg

### Main Features

- CARBON STEEL FRAMING
- Swivel casters with 2 locks
- Onboard storage



RELEASE THE POWER INSIDE





Winntec® is a brand owned by TMG  
Rechtzaad 6, 4703 RC Roosendaal  
The Netherlands  
+31165 394018 | info@winntec.net

winntec.net

We  Jacks

